

# THE GUIDLER

A Guide Idler of Patented & Proven Hyperbolic Design

Tracking control without edge damage for:

**BELT CONVEYORS**  
**WIRE ROPE CONVEYORS**  
**WOVEN WIRE BELTS**  
**VARIOUS TYPES OF WEB OR SHEET MATERIAL**

Also functions as rotating belt shifter on  
**CONE PULLEY DRIVES**

**Awarded Highest Honors as World's BEST Conveyor Belt Control Mechanism at the International Inventors Exposition in Brussels, Belgium**

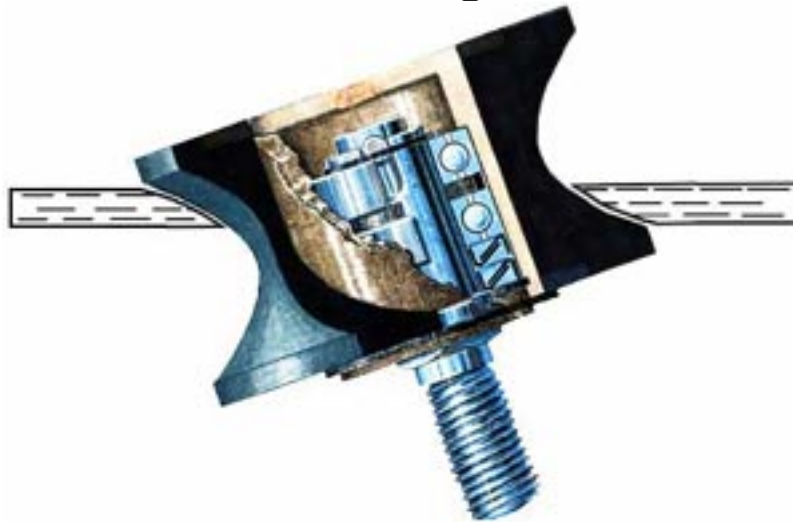

**When properly inclined 30 degrees in direction of belt travel the Guidler provides:**

- Up to 5" of straight line contact to absorb lateral belt loads and eliminate edge curl.
- Belt entrapment to prevent climb-over as is common when using cylindrical guides.
- Axial movement of up to 5/8" to accommodate belt heave and oscillation.
- Quality American manufacture assuring long life and zero maintenance.

# BELT AND WIRE ROPE CONVEYORS

Attempts to control tracking with conventional cylindrical guides are usually unsatisfactory because the lateral forces acting on the belt exceed the belt's resistance to curling as it makes point contact with the guide. Severe belt damage is the result.

When properly inclined at 30 degrees, the hyperbolic design of the Guidler provides a long line contact area up to 5 inches to distribute these forces. In addition, the curve traps and contains the belt edge to prevent curl. Its design also provides for axial accommodate belt flex and heave.

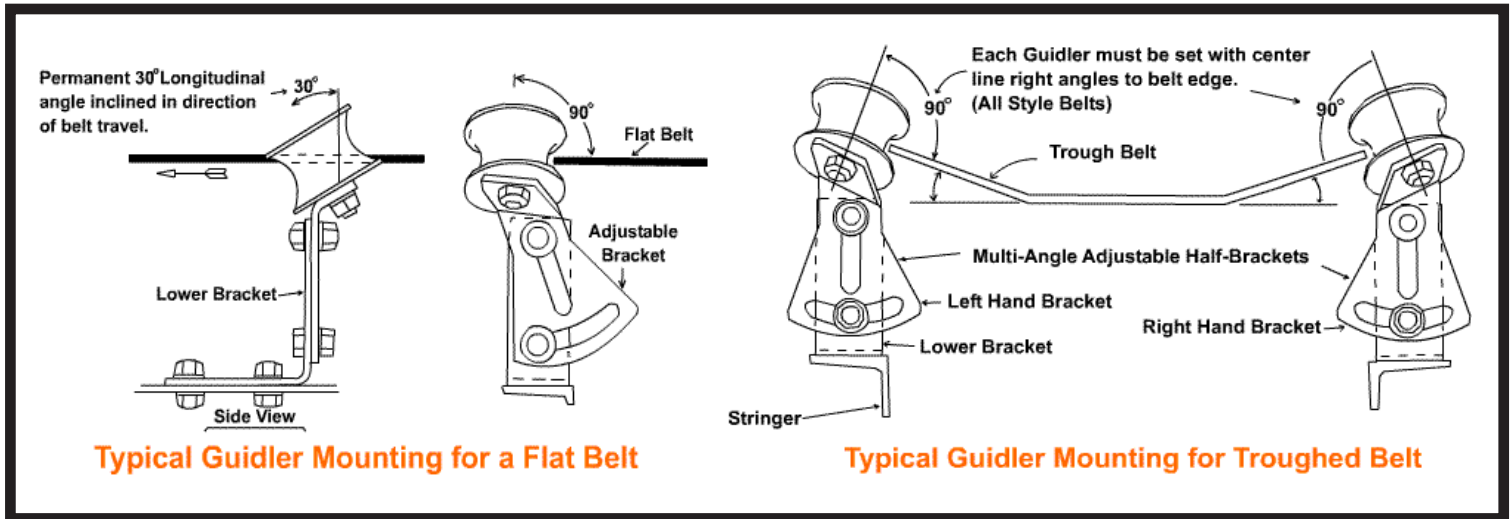

## SELECTION

Multiply the belt width in inches by the square root of the belt speed in feet per minute. Use:

Type R if the result is up to 250 and if the belt thickness is 1/2 max and belt width is 16 max. If either is not the case use type K.

Type K if the result is 250-500 and if the belt thickness is 3/4 max and belt width is 24 max. If either is not the case use type E.

Type E if the result is 500-800 and if the belt thickness is 1" max and belt width is 42 max. If either is not the case use type I.

Type I if the result is 800-1200 and if the belt thickness is 1-1/4 max and belt width is 60 max. If either is not the case or if the result exceeds 1200 a proportional reduction in spacing is required.

## SPACING

**WHEN PROBLEMS AREAS ARE LOCALIZED** there is no need to equip the entire belt. Very often if these local/critical areas are equipped, the remainder of the belt will track within acceptable limits. The installation is then limited to the localized area plus a sufficient lead-in and lead-out. If near the head or tail pulley or belt take-up install one of the pairs within 18 inches of same. See spacing requirements below.

**FOR MODERATE TRACKING PROBLEMS LOCALIZED OR OVER THE ENTIRE LENGTH** (one where the belt's lateral movement can be controlled without deformation with a 3-1/2 inch hand-held piece of material) allow a pair every 32 foot (approx.) on the top side, every 64 foot (approx.) on the return side. Reduce spacing if the belt is especially limber—that is, lacking internal resistance to curl. The end pairs should be within 18 inches of the head and tail pulleys. A pair should be within 18 inches of the belt take-up.

**FOR SEVERE TRACKING PROBLEMS LOCALIZED OR OVER THE ENTIRE LENGTH** every 16 foot (approx.) on the top side, every 32 foot (approx.) on the return side. Reduce spacing if the belt is especially limber—that is, lacking in resistance to curl. The end pairs should be within 18 inches of the head and tail pulleys. A pair should be within 18 inches of the belt take-up.

# MOUNTING

See separate instruction sheet.

## GUIDLER DIMENSIONS

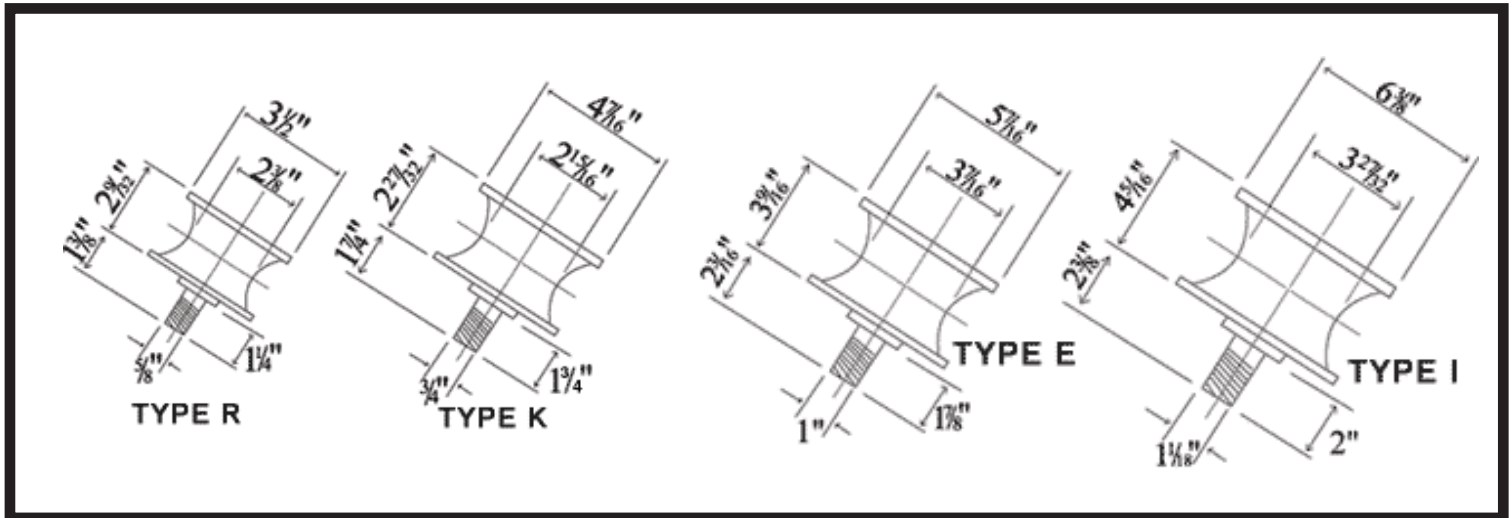

## BRACKET DETAIL

In order to obtain proper positioning and thus assure the elimination of edge curl and climb-over, we have designed and can furnish left and right Multi-Angle Adjustable Half Brackets. These brackets will also greatly facilitate installation and assure the required 30° incline in direction of belt travel and 90° perpendicularity with belt edge.

Fasteners furnished by user unless specifically ordered from us.

Lower brackets must be supplied by user since there are too many possible variables for us to maintain stock.

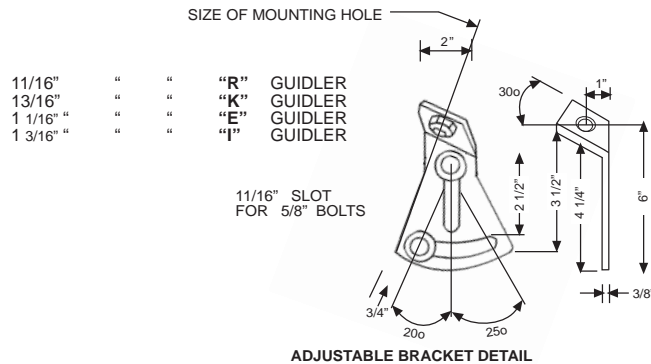
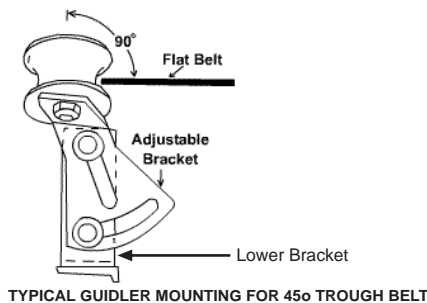

## SAFETY NOTICE

The use of any type of Guidler creates a nip point between the guide and running belt. We can furnish a reasonably priced shield (our Guide Guard) that consists of a ductile iron base plate with a vertical cylindrical post that effectively prevents the accidental placement of hand or glove in the area of danger. We urge you to have your Safety Engineer inspect all guide idler installations.



Representantes para CHILE:

Barahona y Cia Ltda.  
 Málaga 115 Oficinas 1203 - 1205 - Las Condes - Santiago - Chile  
 F: (56-2)22280908 ; Fax: (56-2)22071510  
 Web: [www.barahonaycia.com](http://www.barahonaycia.com) ; email: [info@barahonaycia.com](mailto:info@barahonaycia.com)  
 Sucursal: Av. El Roble 425 Bodega E - Lampa - Santiago - Chile F/Fax: (56-2)27471415

